



Installation instructions

Magic fireplace insert





PREFACE / QUALITY PHILOSOPHY

You have decided in favour of a Spartherm Magic fireplace insert. Thank you for showing confidence in our product. In a world of surplus and mass production, our company stands for the values expressed by our owner, Gerhard Manfred Rokossa:

„High technical quality combined with contemporary design and service to the satisfaction of our customers, so they will recommend us to others“.

Together with our specialist trade partners, we offer a range of first-class products, which not only evoke passion, but also engender feelings of comfort and security in your customers. In order to become completely familiar with your purchase in the shortest possible time, we recommend that you read through these assembly instructions carefully. In addition to detailed instructions on installing your product, this document also contains important safety information, advice on how to keep your Magic in good condition, valuable tips and helpful recommendations. Should you have any further questions or problems, please contact us directly. We are always happy to receive your questions, suggestions and criticisms. We hope you enjoy assembling and using your Magic fireplace insert.

Your Spartherm team

G.M. Rokossa

CONTENTS

1. General instructions	4	5.3 Wooden beams	9
1.1 Certified quality	4	5.4 Insulating layers	9
1.2 Rating plate	5	5.4.1 Insulating material thickness	9
1.3 Installation steps	5	5.4.2 Protecting the mounting wall with a stud wall	10
2. Basic requirements for installing an open fireplace	5	5.5 Special precautions for the fire protection of hardwood beams	10
3. Installation locations and combustion air supply	6	5.6 Expansion between the cladding and the Magic fireplace insert	11
3.1 Basic requirements for open fireplace installations and premises not suitable for fireplace installation	6	5.7 Fireplace apron	11
3.2 Open fireplace operation is dangerous when	6	5.8 Connecting piece	11
3.3 Open fireplaces must not be installed	6	5.9 Thermal output	11
3.4 Combustion air supply	6	5.9.1 Hot air systems	11
3.5 Combustion air piping	7	5.9.2 Closed fireplace systems	11
4. Cut-off device in the vent	7	6. General advice on installation	12
4.1 Throttling devices	7	7. Special precautions for fire protection	14
5. Protection in the area of the firebox opening	8	8. Open fireplace cleaning	14
5.1 Floor area	8	9. Special note	14
5.1.1 Special precautions for the fire protection of flooring installed in the direct vicinity of fireplaces	8	9.1 Smoke tube to be screw from interior room	14
5.2 Concrete and reinforced concrete load-bearing components	9	10. Technical data	15
5.2.1 Special precautions for the fire protection of adjacent components constructed of flammable materials	9		

1. GENERAL INSTRUCTIONS

These installation instructions comply with the provisions outlined in DIN EN 13229 „Solid-fuel fireplaces“.

All national and regional regulations, standards and norms, methods of installation and material specifications must be observed. Our Magic fireplace insert is intended for temporary burning, not for continuous burning. Longer operating periods are only achievable by repeatedly refuelling the fire. Of course, our fireplace inserts are subject to the company's own quality criteria of the incoming goods inspection up to final acceptance prior to shipment.

Small children, elderly or infirm persons:

As is the case with all heating devices, it is expedient that you attach a protective fixture for these groups of persons, as the viewing pane and the cladding parts of the fireplace can become extremely hot!

Danger of burn injuries!

Do not allow children, the elderly or the infirm into the immediate area of the burning or recently extinguished fireplace insert unsupervised! Please ensure that persons belonging to these groups are made aware of the dangers.

No combustible objects, materials or substances should be placed on or near the free surfaces of the fireplace. Do not attempt to dry out clothing on the hot tiles. When drying clothes, use a proper drying stand or clothes' horse and ensure it is placed outside the area of direct radiant heat!

The surfaces of your stove or fireplace (including the operating handles, doors, glasses, etc.) are quickly made hot by heat energy released during the combustion process. Do not attempt to touch these components without adequate protection (i.e. heat-resistant gloves).

Do not attempt in any way to modify the Magic! Do not insert any foreign component (any component not expressly approved by Arcadia) into the combustion chamber, combustion passages or exhaust gas flue. Without such an express agreement, any modification to the fireplace will render your warranty and operating license invalid.

You may find that extractor hoods, ventilation equipment, etc. installed in the same room (or linked space) as your fireplace or stove have a negative effect on the operation of the Magic (such as the release of smoke into the room). These devices should not be used at the same time as your fireplace or stove, without first ensuring that the necessary room heating system precautions have been taken.

When using more than one fireplace in a single room or linked space , ensure that sufficient air is available for complete combustion!

Your appliance is designed to operate as a temporary or short-term combustion device. Combustion cannot continue indefinitely if the supply of air is finite. Long term use can only be achieved by repeatedly refuelling the fire.

Transport damage: Please visually inspect the delivered goods immediately upon arrival (visual inspection). Make a note of any damage on your delivery document. Inform your stove or fireplace fitter of the damage before the installation work begins. When installing the casing of your fireplace insert, take care to protect the viewing glass of your Magic from damage or soiling.

1.1 CERTIFIED QUALITY

OUR FIREPLACE INSERTS COMPLY WITH DIN EN 13229 SPECIFICATIONS AND ARE LABELLED IN CONFIRMATION THEREOF. THE DECLARATION OF PERFORMANCE IS AVAILABLE AND CAN BE VIEWED

A = non-self-closing firebox door

- open operation possible under certain conditions
- no multiple chimney configuration option

A1 = self-closing firebox door

- Closed operating mode
- multiple chimney configuration option

Except when feeding, the firebox on Model A1 should always be kept locked to prevent the escape of hot gases. These fireplace inserts have self-closing combustion chamber doors which means the doors are only opened when the fireplace has to be serviced (e.g., to clean the combustion chamber or add more fuel). Amongst other things, multiple use of the chimney is possible with the Magic. The closing mechanism of model A1 must not be manipulated for safety reasons, moreover this renders the warranty and operating licence null and void. The guarantee and operating licence are also rendered invalid if the customer modified the technology of any other area of the Magic. The desired design should have been clarified with your customers or their responsible master chimney sweep before ordering.

1.2 RATING PLATE

For the Magic fireplace insert, the rating plate is located in the internal recessed inspection door below the firebox door. To reach the inspection door, the firebox first has to be rotated. This can occur either electrically or manually. Grasp the operating handle on the right side of the Magic and, using the heat-protected glove, pull the combustion chamber forward in a clockwise direction. The rear fire door has to be centred in the chimney unit. Tilt the door handle upwards and open the door. To open the inspection door, unscrew the recessed Allen screws. (Fig. 1). Turn the disengaged inspection door around (Fig. 2). The rating plate is located on the bottom (Fig. 3).

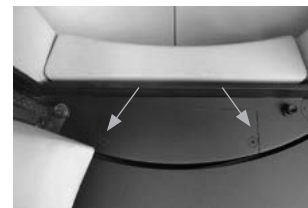

Fig. 1



Fig. 2



Fig. 3

1.3 INSTALLATION STEPS

1. Install the SVS connector either horizontally or vertically.
2. The Magic must stand vertically upright and plumb to the horizon!
3. Connect the Magic Flue gas connection either vertically or horizontally to the chimney.

2. BASIC REQUIREMENTS FOR INSTALLING AN OPEN FIREPLACE

Before installing the Magic, make sure that the air controls function perfectly and repair if necessary. Consult a local expert to establish the condition of the chimney and combustion air intake before beginning installation. Note and apply DIN 18160 and DIN 18896. The relevant provisions of DIN EN 13229 must also be complied with. Each and every fireplace must be

provided with its own chimney. Multiple chimney configuration may only be used on closed operating systems (Type A1). The chimney calculation is based on DIN 4705 T1, T2 or EN 13384-1 with the value triplet specified in these instructions. The deliverable convection jacket can be dispensed with in the case of tile fireplaces. The combustion system must be set up as per the professional tile and ventilation engineer regulations (TROL-Richtlinien für den Bau von Kachelöfen), available from the German Central Association for Sanitation, Heating, and Air Conditioning (ZVSHK), Rathausallee 5, 53729 St. Augustin, Germany).

3. INSTALLATION LOCATIONS AND COMBUSTION AIR SUPPLY

3.1 BASIC REQUIREMENTS FOR OPEN FIREPLACE INSTALLATIONS AND PREMISES NOT SUITABLE FOR FIREPLACE INSTALLATION

Open fireplaces may only be installed in premises, where no danger exists due to location, constructional conditions and building use. In particular, when the model is dependant on indoor air, sufficient combustion air must flow into the room in which the fireplace is set up. The floor area must be of sufficient size and of a suitable design to allow an open fireplace to be properly used.

3.2 OPEN FIREPLACE OPERATION IS DANGEROUS WHEN

- the systems have safety devices that automatically and reliably prevent any vacuum in the installation area or
- the overall combustion air volume flows and air stream volume of the ventilation systems necessary for the open fireplaces require a vacuum in the installation areas of the open fireplaces and premises of the ventilation network equalling more than 0.04 mbar.

3.3 OPEN FIREPLACES MUST NOT BE INSTALLED

- in stairways, unless they are in residential buildings with two or fewer flats
- in hallways with general access
- in garages
- in rooms in which highly combustible or potentially explosive substances or mixtures are processed, stored or manufactured in quantities that would be hazardous in the event of ignition or explosion.

Open fireplaces which require indoor air must not be set up in rooms or flats which are ventilated with ventilators or hot-air heating systems which use fans unless the safe functioning of the open fireplace has been checked and confirmed.

3.4 COMBUSTION AIR SUPPLY

Open fireplaces may only be installed in rooms with at least one door or window opening to the outside of the building or in rooms directly or indirectly linked with other rooms by the same combustion air. When installed in apartments or other functional units, rooms linked with other rooms by the same combustion air can include the same apartment or utilisation unit.

Open fireplaces may only be installed in the aforementioned rooms where the flow of combustion air is at least 360 m³ per hour and the firebox opening is at least x m² in area. Where other fireplaces are installed in the same premises or in areas linked thereto, open fireplaces must be provided with at least 540 m³ of combustion air per hour and have a firebox measuring x m² in area, and the other types of fireplaces must have at least 1.6 m³ of combustion air per hour and per kW total nominal heat output at a calculated pressure difference of 0.04 mbar with respect to atmospheric conditions. An air flow velocity of around 0.15 m/s is generally used for calculating supply pipe diameter. For a fireplace with a door height of 51x60 cm, a feed pipe cross-sectional area of 175 cm² is required, i.e. a supply pipe diameter of ca. 15 cm.

Where the volume of combustion air at the installation is inadequate (e.g., in houses with ventilation systems), a combustion air feed pipe must be connected to the appliance. The combustion air feed pipe is designed to supply the appliance with air from another room. (The source room must have a sufficient supply of air. If in doubt, consult a local expert and refer to the FeuVo and DIN 18896).

A shut-off valve must be installed, where the combustion air feed pipe runs outside the building. It must be possible to easily determine the shut-off valve setting. This arrangement allows the feed pipe to be isolated, in order to guard against the formation of condensation. The pipe should be positioned, so that any condensation formed can run out of the pipe and water or other foreign substances cannot get in.

Note:

In the interests of providing adequate amounts of combustion air, the January 1980 issue of Furnace Regulations for instructions on system design and the May 1998 issue of Furnace Regulations for examples of working systems should be consulted. The templates are published in the notifications of the Institute for Building Technology, No. 3/1980, 17th year (see also the commentary to DIN 18895).

3.5 COMBUSTION AIR PIPING

In accordance with local regulations (Landesbauordnung) pursuant to Article 37 Paragraph 2 of the German Model Building Code, combustion air piping crossing a fire wall in buildings with more than two fully-sized floors must be installed such that smoke or fire cannot be transmitted to other floors or fire compartments.

Note:

For information on how to comply with the above-mentioned specifications, see the fire inspection guidelines for the fire prevention requirements of ventilation systems (draft) – January 1984 version.

4. CUT-OFF DEVICE IN THE VENT

Open fireplaces with Spartherm fireplace inserts may have a cut-off device in the vent. These devices must not be self-closing and must not be positioned such as to prevent or hinder the inspection and cleaning of connecting pipework. The position of the shut-off device must be visible from the outside, e.g., from the position of the operating handle. Shut-off devices may only be installed in the exhaust manifold, the exhaust stack or the connection piece. Instead of cut-off devices, fireplace inserts with combustion chamber doors can have throttling devices.

4.1 THROTTLING DEVICES

Throttling devices may only be installed in the exhaust gas pipe stub or pipeline connecting piece. Throttling devices must be easy to operate. They should have cross-sectional areas at the pipe of at least 20 cm² and not less than 3% of connecting pipe cross-sectional area. The position of the throttling device must be visible upon setting the operating handle.

5. PROTECTION IN THE AREA OF THE FIREBOX OPENING

5.1 FLOOR AREA

The floor area directly in front of fireplaces with closed fireboxes must either be of non-flammable construction or protected by a non-flammable floor covering. The covering must extend from the combustion opening by at least 50 cm to the front and at least 30 cm to the sides.

Where the floor area to the front of an open fireplace is made of flammable materials, these must be protected at the front by a covering of non-flammable material to the height of the andiron or firebox base (floor height plus 30 cm, but a minimum of 50 cm) and at the side to the height of the andiron or firebox base (floor height plus 20 cm, but a minimum of 30 cm). If a log guard measuring at least 10 cm in height has been installed, fire protection of 50 cm at the front and 30 cm at the sides is sufficient.

The non-flammable covering may be made of ceramic (such as tiles or flagstones), natural stone or mineral materials (such as marble or granite), metal at least 1 mm thick or suitably sturdy and heat-resistant glass. The covering must be secured to prevent it from unintentional sliding.

5.1.1 SPECIAL PRECAUTIONS FOR THE FIRE PROTECTION OF FLOORING INSTALLED IN THE DIRECT VICINITY OF FIREPLACES

Carpets and parquet flooring must be protected from spark emission using a covering made from non-flammable materials (e.g. natural stone).

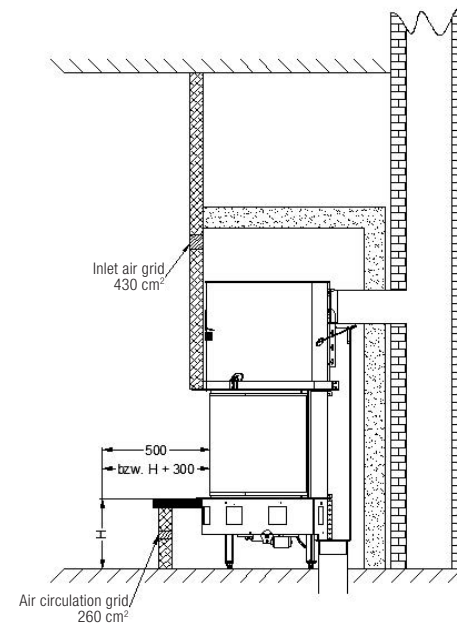
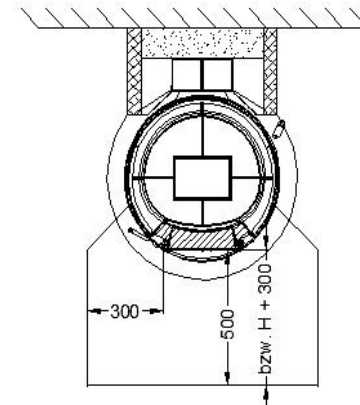

5.2 CONCRETE AND REINFORCED CONCRETE LOAD-BEARING COMPONENTS

Open fireplaces must be installed such that hot air discharge vents are positioned at least 30 cm distant from concrete or reinforced concrete load-bearing components.

5.2.1 SPECIAL PRECAUTIONS FOR THE FIRE PROTECTION OF ADJACENT COMPONENTS CONSTRUCTED OF FLAMMABLE MATERIALS

1. A minimum clearance of 50 cm must be maintained between the fireplace casing and any adjacent fixtures.
2. A clearance of at least 10 cm is recommended for components with small contact areas (wall, floor or ceiling cladding).
3. A clearance of at least 800 mm must be maintained to the front, back and sides of the firebox opening and all components made of combustible materials or combustible components, as well as built-in furniture, unless stated otherwise in component-specific safety instructions.
4. In the arrangement of a radiation protection which is ventilated on both sides, a distance of 400 mm is sufficient. The ventilated distance of the radiation protection must be at least 20 mm.

5.3 WOODEN BEAMS

Wooden beams must not be exposed to the radiant heat emitted by the Magic. Wooden beams positioned above an open fireplace must be fully ventilated and a minimum clearance of 1 cm must be maintained. Direct anchorage with thermal bridges is not permitted.

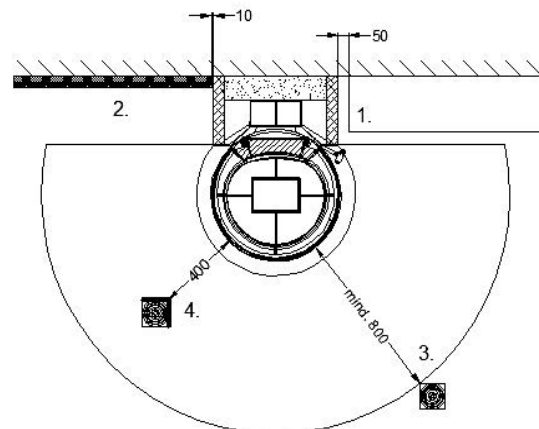

5.4 INSULATING LAYERS

Based on the information provided by the test institutes and the applicable standards, all statements regarding insulation material refer to mineral wool as a reference insulation material, as elaborated below in point 6 and 7. Other suitable insulating materials may be used as an alternative. The materials used must be approved by the DIBt (German Institute of Building Technology) and provided with certificates or marking in confirmation thereof.

5.4.1 INSULATING MATERIAL THICKNESS

to the setup floor:	-
to the mounting wall:	11 cm
to the ceiling:	-
to the side wall:	-

(Data refer to rock wool mats according to AGI-Q 132)

Mats, sheets or shells of silica-based insulation material (stone or slag and ceramic fibres) of material class A1 as per DIN 4102, part 1 with an upper

application limit temperature of at least 700°C when measured as per DIN 52271 and a rated gross density of 80 kg/m³ are to be used to produce the insulating layers (see Special information on insulation of the mounting wall/side wall). These must be provided with a suitable AGI-Q 132 insulating material code number.

The code number of the insulating material used must not, however, contain the code sequence „99“! Where the insulating layer is not held in place by walls, cladding or plating, it should be pinned into position at a maximum distance of 33 cm between the pins. Other insulation materials, e.g., gas concrete or mineral construction materials, must be approved by the German Institute of Building Technology in Berlin (DIBt). These must be constructed in accordance with the manufacturer's specifications.

The individual insulation materials have different coefficients of thermal conductivity which means the insulation material thicknesses will vary. The required insulation material thickness can be taken from the diagram provided by the insulation material manufacturer.

Some thermal insulation materials can be used as a stud wall and insulation at one and the same time. This significantly reduces installation depth. Thermal insulation made of stone and slag fibre require abrasion-resistant cladding, so that the recirculating air does not transport insulation particles into the room. Other thermal insulation sheets leave the factory with added abrasion resistance as required. This type of insulation material may only be installed offset and all joints must be sealed. Where multiple insulation layers are required, the joints should be arranged to overlap.

5.4.2 PROTECTING THE MOUNTING WALL WITH A STUD WALL

- A protective stud wall must be constructed when installing a wall-mounted open fireplace. The stud wall must protrude at least 20 cm beyond the connecting piece.
- The stud wall may be omitted if the building wall:
 - is at least 11.5 cm thick

- consists of non-combustible components
- is not a concrete or reinforced concrete wall
- Stud walls are normally of brick construction, but may also be constructed from the heat-insulating panels referred to above, in order to reduce the total thickness of the stud wall and insulating material.

5.5 SPECIAL PRECAUTIONS FOR THE FIRE PROTECTION OF HARDWOOD BEAMS

1. The beam must be located outside the radiation area.
2. The ventilated distance must be at least 10 mm or
3. a dimensionally stable insulation sheet with a thickness of approximately 20 cm must be provided and attached to the underside of the beam.
4. The gap between the inner edge of the combustion gas manifold and the mantel has to be at least 165 mm.

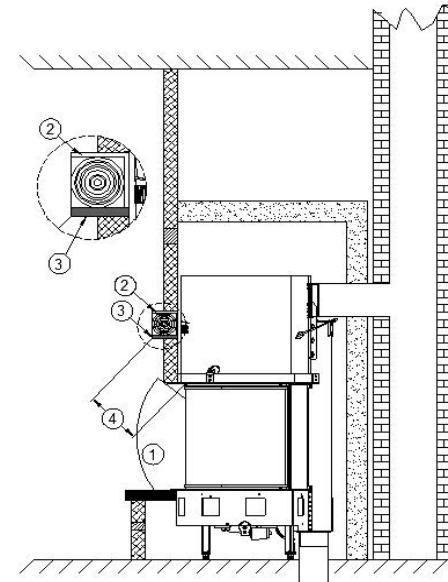

5.6 EXPANSION BETWEEN THE CLADDING AND THE MAGIC FIREPLACE INSERT

There must not be any direct connection between the Magic and the cladding. An expansion joint must be provided and sealed by means of an appropriate sealing strip.

5.7 FIREPLACE APRON

There must not be a direct connection between the Magic and the apron. The apron must be self-supporting. Please note that there must be a minimum distance of 6 mm between the door frame and the fireplace hood/installation frame in order to be able to disassemble the fireplace insert door if necessary (e.g. replace the pane).

5.8 CONNECTING PIECE

The connecting piece end stub is located in the exhaust port of the Magic. The connection to the chimney is to be as direct as possible and can be either vertical and horizontal. Chimney connections are best effected using walled-in ducting, or arranged as specified by the flue manufacturer. Connecting pieces for domestic chimneys are made to shape from fireclay or steel piping of at least 2 mm steel sheet pursuant to DIN 1623, DIN 1298 and DIN EN 1856.

Discharge pipes running within the casings of open fireplaces must be manufactured from 3-cm thick, deformation-resistant, non-flammable Class A1 rock wool matting to DIN 4102 Part 1 with an upper threshold temperature of at least 750 °C when tested pursuant to DIN 52271 and coated with a binding agent not greater than 1.2%. An increased thickness of 6 cm is required if the cladding of the exhaust gas collector is made of metal. The above is not required if the connecting piece is designed specifically for the convective heating of the ambient air. NOTE: connecting piece specifications are covered by DIN 18160 Part 2.

5.9 THERMAL OUTPUT

Since it is possible to use different fireplace types with our fireplace inserts, it is essential to consult a professional company when planning a fireplace. Make sure that the level of heat dissipation is sufficient. This can be achieved by using convection air ducts in the cladding or heat-dissipating cladding elements.

5.9.1 HOT AIR SYSTEMS

Fireplace systems designed to transfer heat by convection (stoves, fireplaces, etc.) must comply with the following points:

- The cross section for the air inlet opening and for the air outlet opening can be found in the technical data. Different cross sections are possible if substantiated by calculations.
- It must not be possible to close at least 50% of the air inlet and air outlet openings.
- Air circuit pipes must be manufactured from a non-flammable, non-deformable material.
- No flammable objects or materials (wooden ceiling components, furniture) may be positioned within an area 30 cm to the side of, and 50 cm above the system hot air discharge grilles.

5.9.2 CLOSED FIREPLACE SYSTEMS

Systems in which hot air is transmitted across the external surfaces of the fireplace (stoves, hypo-caustic units, devices with closeable convection air openings, etc.), i.e. to the surroundings via radiation from the casing surfaces, must comply with the following points:

- The fireplace system must be designed and installed in accordance with KL industry specifications (now governed by TR OL 2006).
- We recommend the use of sufficient storage material (e.g. Mag-netherm), in order to guarantee optimal heating and prevent over-heating due to temperature peaks.
- Stove dimensions, i.e. the size of the heat-transmitting surfaces, will be dependent on thermal output and heating requirements!
- Fireplace casing components must be selected to meet the heightened requirements.
- The installer is obliged to inform the operator (preferably in writing) of any special constructional or operating features. The amount of wood used must correspond to the heat-transmitting properties of the surface and the storage capacity of the storage medium (as a general rule, the fire should not need refuelling more than 2 - 3 times per day).
- It is recommended, that contacting surfaces manufactured from flammable substances be protected by ventilation.
- The given insulation thicknesses only apply to hot air systems. Closed fireplace systems must be heat insulated in compliance with TROL specifications.
- When fitting components, ensure that the manufacturer's installation guidelines are strictly adhered to, especially in respect of allowable operating or ambient temperature and (wherever possible) accessibility.

6. GENERAL ADVICE ON INSTALLATION

Floors, ceilings and mounting walls made of non-combustible construction materials Important Note: The Magic must not be mounted on floating floor screed. Floor screeds must be appropriately anchored.

Key:

1. All-round insulation of the air chamber, at least 11 cm of insulation (with rock wool mats according to AGI-Q 132)
2. Sealing cord
3. Wall lining without sleeve
4. Exhaust pipe (connecting piece)
5. Supply air grid (hot air outlet)
6. Air chamber
7. Facing brickwork (constructed from non-flammable materials)
8. Mounting frame (not stored directly on the fireplace insert)
9. Insulating strips
10. Spartherm Magic fireplace insert
11. Fresh air inlet valve
12. Recirculating air grille (cold air intake)
13. Exhaust pipe extension
14. Chimney

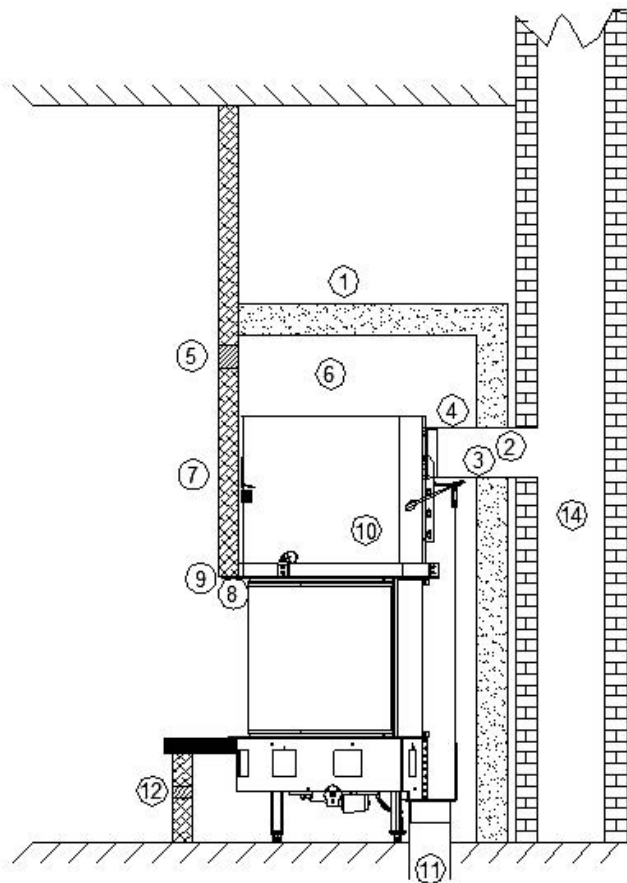

horizontal flue pipe connection

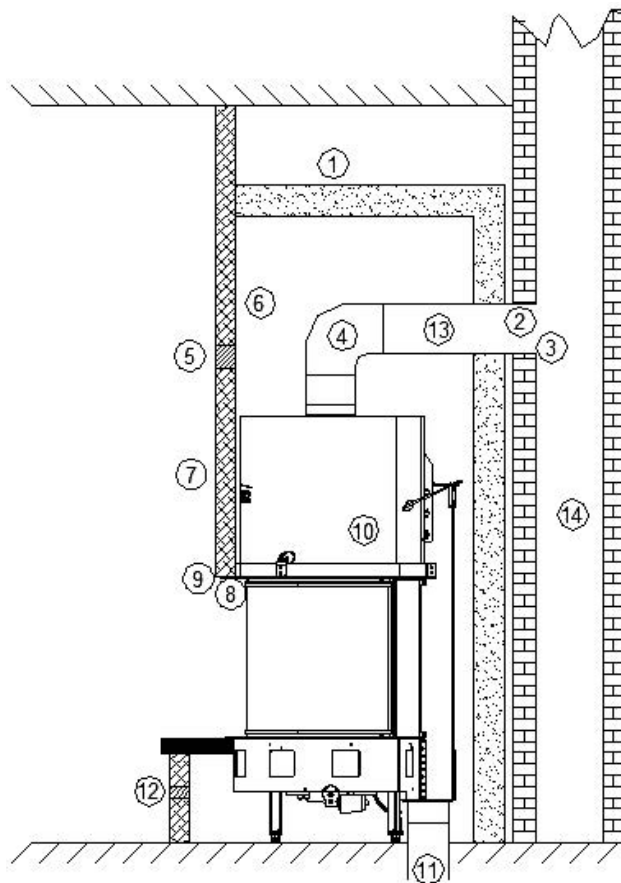

vertical flue pipe connection

7. SPECIAL PRECAUTIONS FOR FIRE PROTECTION

Key:

1. Components manufactured from flammable materials (or load-bearing walls constructed from reinforced steel)
2. Wall constructed from mineral-based building components, at least 10 cm in thickness
3. Connecting piece insulation consisting of at least 3-cm thick, non-deformable mineral wool
4. Facing brickwork made of non-flammable materials
5. Insulation from non-deformable rock wool mats pursuant to AGI-Q 132, with a thickness of 11 cm
6. Non-deformable mineral wool insulation, 8 cm thick
7. Small area heat bridge
8. Concrete slab, at least 6 cm thick

8. OPEN FIREPLACE CLEANING

Open fireplaces must be designed such that supply air piping can be easily cleaned. The clearances to ceilings, walls and sundry fixtures must be easy to identify and kept clear at all times. The connecting piece and chimney must be easily accessible for cleaning purposes.

9. SPECIAL NOTE

9.1 SMOKE TUBE TO BE SCREW FROM INTERIOR ROOM

The smoke tube of the Magic can be connected either vertically or horizontally with a diameter of \varnothing 180 mm.

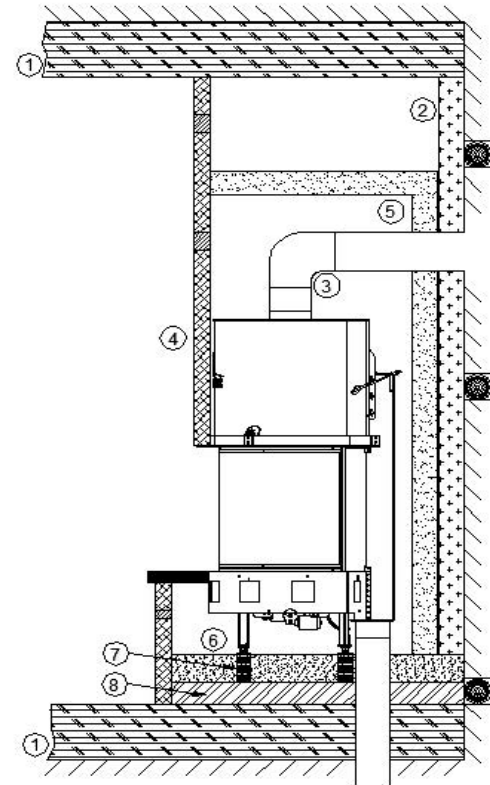

10. TECHNICAL DATA

We reserve the right to make alterations and do not accept any liability with regard to any errors made. * regarding combustible and protective components

General data	
Nominal heat output (kW) (closed operation)	12.0
Thermal output range (kW)	8.4 - 15.6
Efficiency (%)	> 80
Recommended chimney diameter (mm)	180
Exhaust gas connection diameter (mm)	180
Weight kg (approx.)	295
Required minimum cross section for supply and recirculated air (cm ²)	430 / 260
Operating with an open firebox (multiple configuration not permitted)	
Mass flow of flue gas (g/s)	-
Flue gas temperature (°C)	-
Required supply pressure (Pa)	-
Recommended volume compensation (cm)	-
Operating with a closed firebox (multiple configuration permitted)	
Mass flow of flue gas (g/s)	9.0
Flue gas temperature (°C)	370
Required supply pressure (Pa)	11
CO ₂ (%)	11.6
Required diameter pursuant to M-FeuVo (cm)	15
Combustion air requirement (m ³ /h)	29

Heat distribution	
Convection (%)	47
Viewing pane (%)	53
H ₂ O (%)	-
Distances of heating chamber	
to the heating chamber wall (cm)	8.5
to the setup floor (cm)	-
Insulation* (for example: rock wool mats pursuant to AGI Q 132)	
Mounting wall (cm)	11
Supporting floor (cm)	-
Side walls (cm)	-
Cladding in the case of a wall that has to be protected (cm)	10
Tests and values	
Design A	-
Design A1	✓
BlmsCHV Tier 1 / Tier 2	✓ / ✓
15a BVG	✓

SPARTHERM

The global brand for your lounge

<u>Reg. no.:</u>	<u>Product inspected by:</u>	<u>Date:</u>

		Day Month Year
<hr/>		
Your specialist dealer:		

